

■ Dimensions

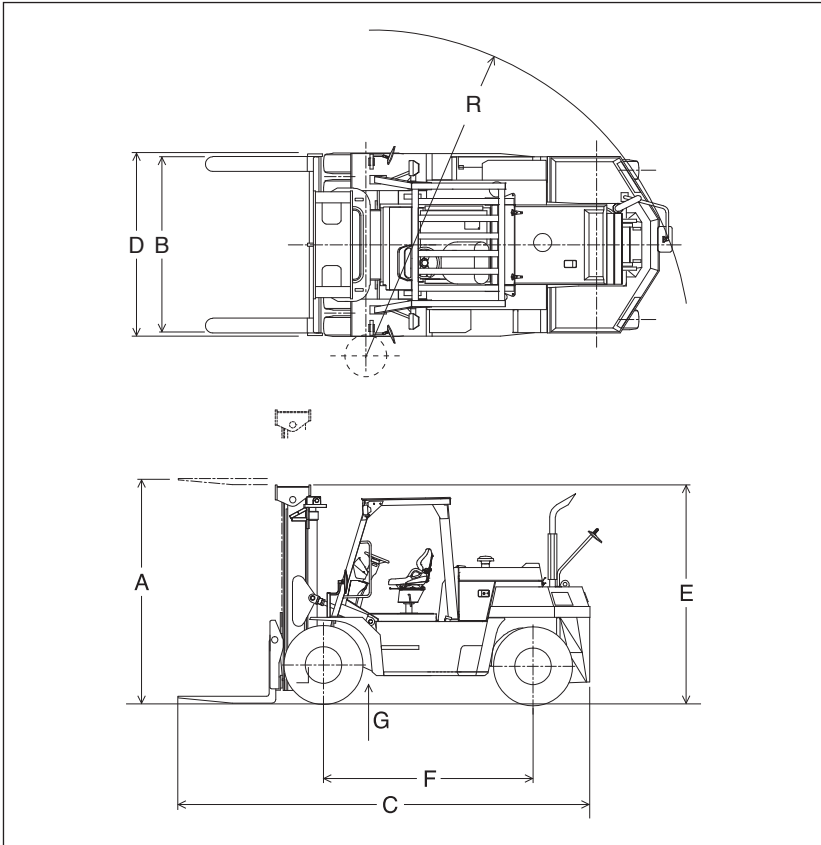

■ Load Charts

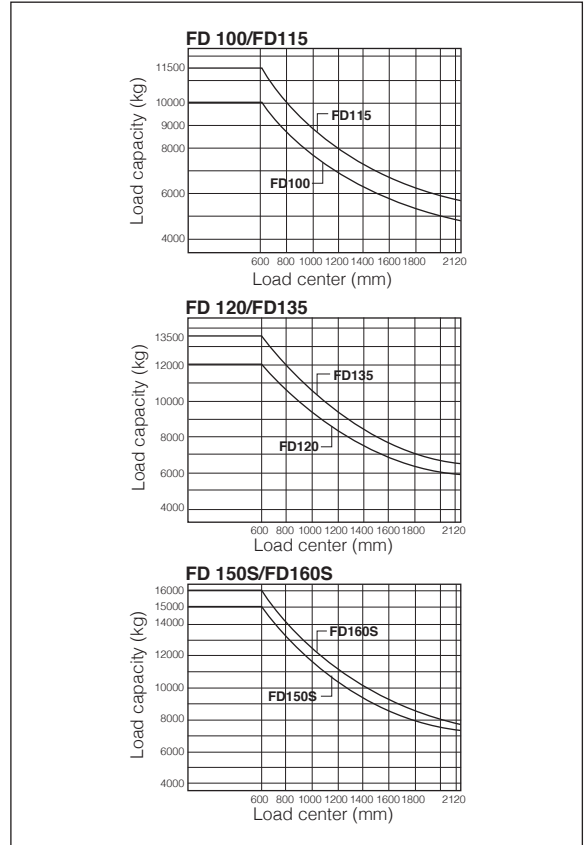

■ Standard Specifications

Model		FD100-3H	FD115-3	FD120-3	FD135-3	FD150S-3	FD160S-3	
Performance	Load capacity	kg (lbs)	10000 (22000)	11500 (25500)	12000 (26500)	13500 (30000)	15000 (33000)	16000 (35000)
	Load center	mm (in)	600 (24)	600 (24)	600 (24)	600 (24)	600 (24)	600 (24)
	Maximum fork height	mm (in) A	3000 (118.1)	3000 (118.1)	3000 (118.1)	3000 (118.1)	3000 (118.1)	3000 (118.1)
	Lifting speed : with load	mm/s (fpm)	460 (90.5)	450 (88.6)	450 (88.6)	350 (68.9)	340 (66.9)	340 (66.9)
	Mast tilt angle : forward / backward	deg	6 / 12	6 / 12	6 / 12	6 / 12	6 / 12	6 / 12
	Max. Travel speed	km/h (mph)	34 (21.1)	34 (21.1)	34 (21.1)	34 (21.1)	34 (21.1)	34 (21.1)
	Lateral fork adjustment (outside)	mm (in) B	400 ~ 2140 (15.7~84.3)	400 ~ 2140 (15.7~84.3)	400 ~ 2140 (15.7~84.3)	470 ~ 2210 (18.5~87.0)	470 ~ 2210 (18.5~87.0)	470 ~ 2210 (18.5~87.0)
	Turning radius (outside)	mm (in) R	4000 (157.5)	4000 (157.5)	4000 (157.5)	4300 (169.3)	4300 (169.3)	4450 (175.2)
Gradeability : with load (1.6km/h)	%	47	39	38	33	30	29	
Dimensions & Weight	Overall length : with fork	mm (in) C	5490 (216.1)	5505 (216.7)	5505 (216.7)	5775 (227.4)	5775 (227.4)	5920 (233.1)
	Overall length : without fork	mm (in)	4285 (168.7)	4285 (168.7)	4285 (168.7)	4545 (178.9)	4545 (178.9)	4685 (184.4)
	Fork size : L x W x T	mm (in)	1220 x 180 x 75 (48.0 x 7.1 x 3.0)	1220 x 180 x 90 (48.0 x 7.1 x 3.5)	1220 x 180 x 90 (48.0 x 7.1 x 3.5)	1220 x 200 x 85 (48.0 x 7.9 x 3.3)	1220 x 200 x 85 (48.0 x 7.9 x 3.3)	1220 x 200 x 90 (48.0 x 7.9 x 3.5)
	Overall width	mm (in) D	2240 (88.2)	2280 (89.8)	2280 (89.8)	2360 (92.9)	2360 (92.9)	2360 (92.9)
	Overall height : mast	mm (in) E	2895 (114.0)	2915 (114.8)	2915 (114.8)	3150 (124.0)	3150 (124.0)	3150 (124.0)
	Overall height : overhead guard	mm (in)	2740 (107.9)	2755 (108.5)	2755 (108.5)	2775 (109.3)	2775 (109.3)	2775 (109.3)
	Wheelbase	mm (in) F	2800 (110.2)	2800 (110.2)	2800 (110.2)	3100 (122.0)	3100 (122.0)	3100 (122.0)
	Ground clearance	mm (in) G	255 (10.0)	275 (10.8)	270 (10.6)	255 (10.0)	255 (10.0)	255 (10.0)
Total weight	kg (lbs)	13250 (29211)	14370 (31680)	14680 (32364)	15900 (35060)	16750 (36927)	17110 (37721)	
Engine & Transmission	Internal combustion engine : model		ISUZU 6BG1T Diesel Engine					
	Internal combustion engine : piston displacement	lit. (in ³)	6.494 (396.3)					
	Internal combustion engine : rated output / engine speed		114kW (155PS) / 2000r.p.m. (SAE GROSS 117kW (157HP) / 2000r.p.m.)					
	Internal combustion engine : maximum torque / engine speed		537N·m (54.8kgf·m) / 1800r.p.m.					
Transmission	Transmission : type		Automatic power-shift transmission					
	Transmission : number of speeds		3 - 3 (Fwd / Rvs)					
Tire & Brake	Tire size		9.00-20-14PR	10.00-20-16PR	10.00-20-16PR	11.00-20-16PR	11.00-20-16PR	11.00-20-18PR
	Brake	Brake : service	Air-over-hydraulic internal expansion					
		Brake : parking	Built in transmission, wet multiple disc brake					
Steering system		Full hydrostatic power steering						

■ Wide View Mast

Mast Model	Capacity												Max. Fork Height		Overall Mast Height (lowered)					
	Load center 600mm(24in)														FD 100-3H		FD115-FD120-3		FD135-FD160S-3	
	FD 100-3H		FD 115-3		FD 120-3		FD 135-3		FD 150S-3		FD 160S-3		mm	in	mm	in	mm	in	mm	in
VM300	10000	22000	11500	25500	12000	26500	13500	30000	15000	33000	16000	35000	3000	118.1	2895	114.0	2915	114.8	3150	124.0
VM350	10000	22000	11500	25500	12000	26500	13500	30000	15000	33000	16000	35000	3500	137.8	3145	1243.8	3165	124.6	3400	133.9
VM400	10000	22000	11500	25500	12000	26500	13500	30000	15000	33000	16000	35000	4000	157.5	3395	133.7	3415	134.4	3650	143.7
VM450	10000	22000	11500	25500	12000	26500	13500	30000	15000	33000	16000	35000	4500	177.2	3645	143.5	3665	144.3	3900	153.5
VM500	10000	22000	11500	25500	12000	26500	13500	30000	15000	33000	16000	35000	5000	196.9	3895	153.3	3915	154.1	4150	163.4
VM550	9000	19800	10350	22800	10800	23800	12150	26700	13500	30000	14400	31700	5500	216.5	4145	163.2	4165	164.0	4400	173.2
VM600	8000	17600	9200	20200	9600	21100	10800	23800	12000	26500	12800	28200	6000	236.2	4395	173.0	4415	173.8	4650	183.1

Mast Model	Overall Mast Height (raised)						Tilt Angle	Service Weight												
	FD 100-3H		FD115-FD120-3		FD135-FD160S-3			Fwd / Bwd	FD 100-3		FD 115-3		FD 120-3		FD 153-3		FD 150S-3		FD 160S-3	
	mm	in	mm	in	mm	in	degree	kg	lbs	kg	lbs	kg	lbs	kg	lbs	kg	lbs	kg	lbs	kg
VM300	4395	173.0	4415	173.8	4650	183.1	6 / 12	13250	29220	14370	31690	14680	32370	15900	35060	16750	36930	17010	37510	
VM350	4895	192.7	4915	193.5	5150	202.8	6 / 12	13350	29440	14470	31900	14780	32590	16020	35320	16870	37190	17130	37770	
VM400	5395	212.4	5415	213.2	5650	222.4	6 / 12	13450	29660	14570	32130	14880	32810	16250	35830	17100	37700	17360	38280	
VM450	5895	232.1	5915	232.9	6150	242.1	6 / 12	13700	30210	14820	32680	15130	33360	16390	36140	17240	38010	17500	38580	
VM500	6395	251.8	6415	252.6	6650	261.8	6 / 12	13800	30430	14920	32890	15230	33580	16490	36360	17340	38230	17600	38810	
VM550	6895	271.5	6915	272.2	7150	281.5	6 / 12	13900	30650	15020	33120	15330	33800	16600	36600	17450	38470	17710	39050	
VM600	7395	291.1	7415	291.9	7650	301.2	6 / 12	14000	30870	15120	33340	15430	34020	16710	36840	17560	38720	17820	39290	

■ STANDARD EQUIPMENT AND ACCESSORIES

[Equipment]

- Adjustable suspension seat with seat belt
- Air-dryer for brake line
- Cartridge type air, fuel, engine oil, converter oil and hydraulic filters
- Coolant recovery system
- Cyclopack type double element air cleaner
- Cylinder type bonnet latch
- Drawbar hook
- Durable overhead guard
- Electrically-controlled parking brake
- Engine after glow system
- Engine auto glow system
- Engine oil dipstick
- Front dual drive wheels
- Full hydrostatic power steering
- Hydraulic oil gauge (view level)
- ISUZU diesel engine with turbo-charger
- Lift circuit flow control valve
- Load check valve
- Overhead exhaust system
- Pneumatic tires
- Power brake booster
- TCM automatic 3-speed powershift transmission
- Tilt adjustable steering post
- Tilt lock valve
- Torque converter oil dipstick
- Wide view mast
- 1220mm forks

[Accessories]

- Back-up buzzer
- Electric horn
- Head lights
- Operator tool kit
- Rear combination lights (turn signal, tail, stop, back-up and side lights)
- Rear reflectors
- Rear under-view mirror
- Rear view mirrors
- Seat adjust lever
- Turn signal lights (front)

[Switch & Controls]

- Automatic transmission mode select switch (power mode / economy mode)
- Electrically-controlled direction change lever (inc. Neutral safety lock device)
- Electrically-controlled parking brake switch
- Lift lever
- Light switch
- Preheater switch (inc. starter, main switch)
- Speed change hold switch (1st fixed / 2nd fixed / Automatic speed shift)
- Tilt lever
- Turn signal lever (inc. dimmer and head light switch)

[Instruments]

- Air cleaner clogging warning indicator
- Brake air pressure meter
- Brake air pressure warning indicator
- Brake oil level warning indicator
- Charge indicator
- Converter oil temperature warning indicator
- Engine oil pressure warning indicator (inc. engine oil filter clogging warning)
- Engine water temperature meter
- Fuel meter
- Hourmeter
- Parking brake indicator
- Speedometer
- Turn signal indicator

■ OPTIONAL EQUIPMENT AND ACCESSORIES

[Equipment]

- CFC free air-conditioner
- Exhaust purifying muffler
- Fork extension sleeves
- Fork positioner (hydraulic motor type)
- Fork positioner (manual type)

- Heater & defroster
- High mast
- Long forks
- Side shifting device
- Steel cabin

[Accessories]

- Central greasing system (manual pump type)
- Fire extinguisher
- Rotating warning light
- Working light (front, rear)

* TCM products and specifications are subject to change without notice.